

ADAC/5500™ Series

Low-Cost, 12-Bit PCI Data Acquisition Boards

Features

- Low-cost, high-quality, multifunction PCI boards
- 12-bit, 100-kHz A/D converter
- 8 differential or 16 single-ended analog inputs (software selectable per channel)
- 100% digital calibration
- Two 16-bit analog outputs with waveform capability
- 48 digital I/O lines
- Two counter input channels

Software

- Includes support for Visual Basic®, C/C++, and LabVIEW®
- PlotterX Plus™ *Out-of-the-Box™* software included with all boards, providing full analog input capability, real time display, and ability to save directly to Excel™

See *DaqBoard/1000 series*
for other low-cost PCI boards

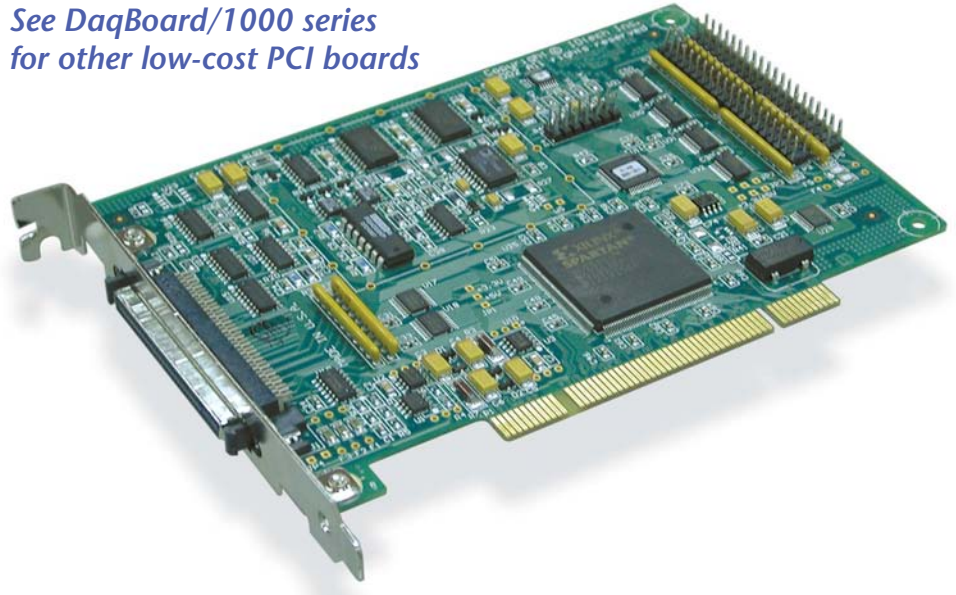

The **ADAC/5500™** series of PCI data acquisition boards provide a high-quality and low-cost alternative to PCI boards from other suppliers. The ADAC/5500 series is ideally suited for OEM applications, and applications where external signal conditioning and expansion options are not required. By targeting these applications, we're able to offer the ADAC/5500 series boards at a very low cost, yet maintain high quality and performance that is comparable to our full-featured **DaqBoard/2000** Series boards.

All boards feature plug-and-play operation (no jumpers or switches), digital calibration (no potentiometers), and DMA operation so that your PC's processor is free to perform other tasks while the **ADAC/5500** series is streaming data directly to your memory or hard drive. Unlike other suppliers that require you to purchase drivers for an additional cost-per-board, the ADAC/5500 series includes Windows drivers for popular languages, as well as LabVIEW drivers.

The **ADAC/5500** series of low-cost, multifunction PCI plug-in boards

ADAC/5500 Series Selection Chart			
Feature	ADAC/5500MF	ADAC/5501MF	ADAC/5501MF-V
Analog Inputs	8 single-ended	8 differential or 16 single-ended	8 differential or 16 single-ended
Analog Input Resolution	12 bit	12 bit	12 bit
A/D sample rate	100 kHz	100 kHz	100 kHz
Analog Outputs (16-bit)	0	0	2
Digital I/O	16	16/48*	16/48*
Counters (16-bit)	2	2	2

* 48 digital I/O lines requires use of (2) CA-G17-ADAC cables

Software Support

ADAC/5500 series PCI boards are supported by 2 levels of software to suit any application or programming skill level.

PlotterX Plus™

Each ADAC board includes PlotterX Plus, an easy-to-use data acquisition and display package that requires no programming. PlotterX Plus allows you to acquire

data from up to 16 analog input channels. Data can be displayed in real-time, logged to a file, and saved in Excel format for data manipulation and display.

Multiple PlotterX Plus packages can run simultaneously on a PC, allowing the use of multiple ADAC/5500 data acquisition boards. PlotterX Plus supports Windows®.

ADAC/5500™ Series

General Information

API Library, & LabVIEW® Drivers

ADLIB-WDM is a complete API library for Windows®, for C/C++ and Visual Basic®, and is included free with each ADAC/5500 series board. ADLIB-WDM includes an extensive user manual and detailed example programs for analog input, analog output, and digital I/O. In addition to the complete API library, drivers for LabVIEW® are also included with each board.

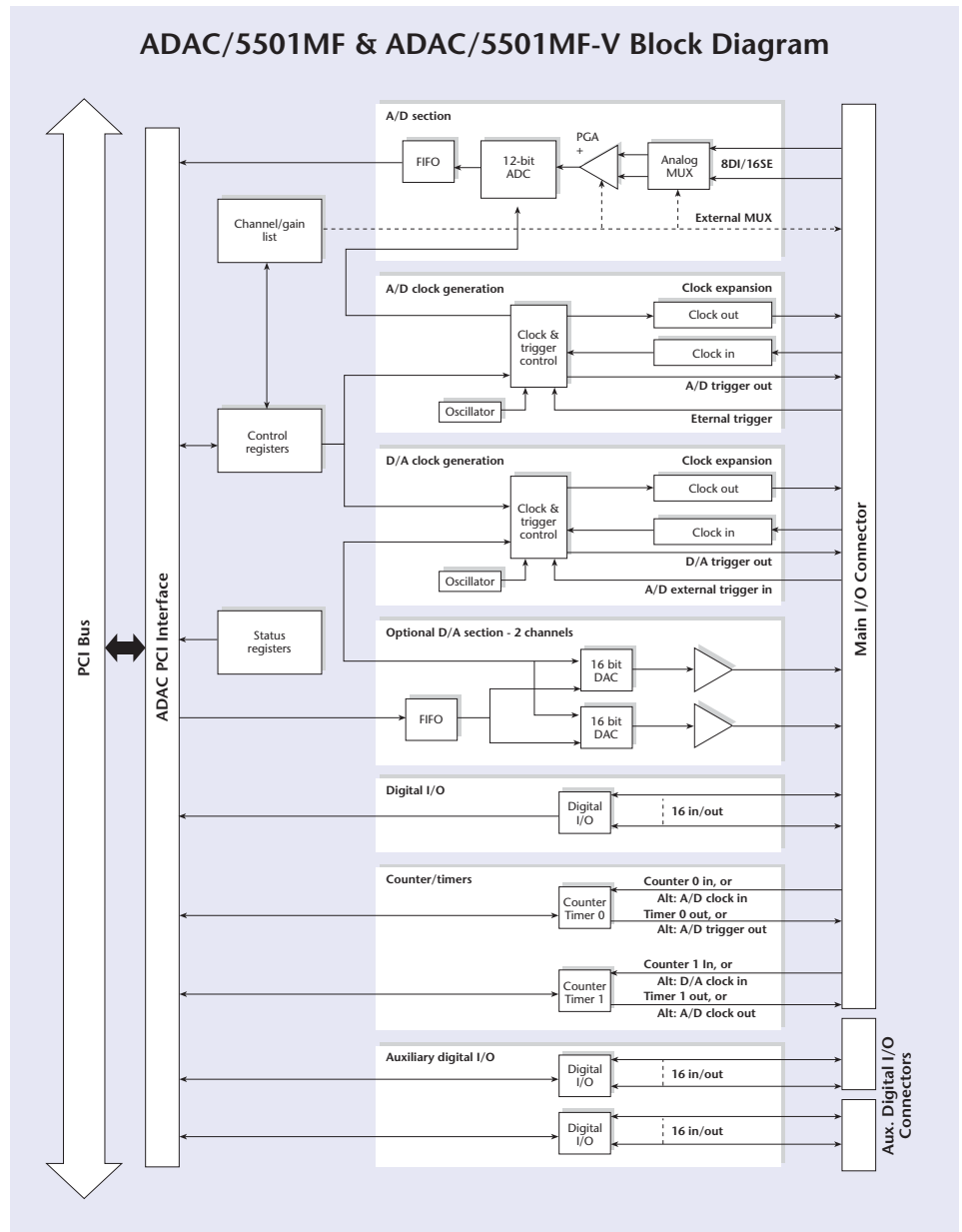

ADAC/5500™ Series

General Information

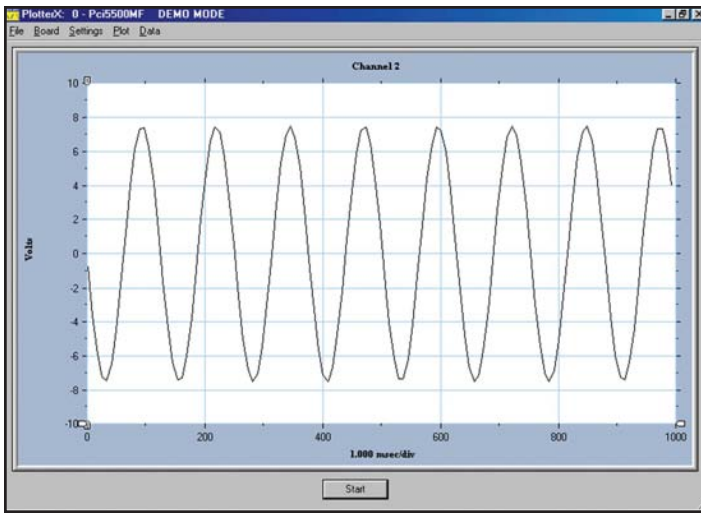

PlotterX Plus provides real-time display and data collection without programming

ADAC-TB-8 Screw-Terminal Board

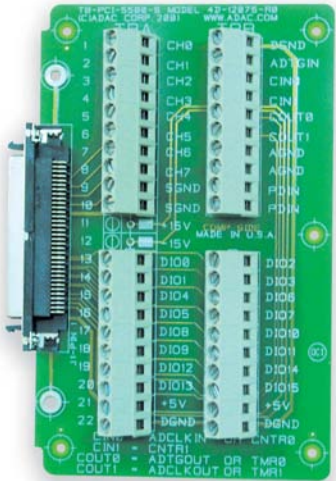

The [ADAC-TB-8](#) provides access to all analog and digital I/O signals from the ADAC/5500MF board via screw-terminals. The board measures 13.41 cm x 8.38 cm (5.28" x 3.30"), accepts up to 14 AWG wire, and connects to /5500MF via CA-G55 or CA-G56 cable.

ADAC-TB-16 Screw-Terminal Board

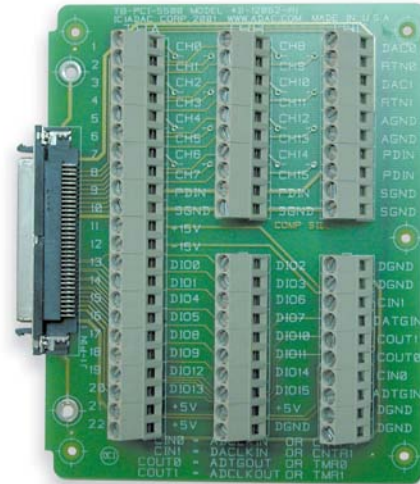

The [ADAC-TB-16](#) provides access to analog and digital I/O signals from the ADAC/5501MF, /5501MF-V, and I/O on the main 68-pin connector (8/16 analog inputs, 16 digital I/O, 2 counters, and 2 optional analog outputs) via screw-terminals. The board measures 13.41 cm x 10.16 cm (5.28" x 4.20"), accepts up to 14 AWG wire, and connects to /5500 series via CA-G55 or CA-G56 cable.

ADAC-DC-37 Screw-Terminal Board for Auxiliary Digital I/O



The [ADAC-DC-37](#) provides access to 16 of the 32 available auxiliary digital I/O channels from ADAC/5501MF, and /5501MF-V boards. Two ADAC-DC-37s are required to access all 32 auxiliary digital I/O channels. The board measures 13.41 cm x 6.35 cm (5.28" x 2.5"), and connects to /5500 series via CA-G17-ADAC (required) and CA-G37-x-ADAC (optional) cable.

ADAC/5500™ Series

Specifications

Specifications

General (all boards)

Operating Temperature: 0°C to 55°C

Signal I/O Connector: 68-pin standard "SCSI Type III" female connector

Dimensions: 141 mm W x 15 mm x 106 mm H (5.57" x 0.6" x 4.2")

A/D Specifications

Type: Successive approximation

Resolution: 12 bit

Maximum Sample Rate: 100 kHz

Nonlinearity (Differential): ±0.9 LSB, no missing codes

Analog Inputs*

Channels

/5500MF: 8 single-ended

/5501MF, /5501MF-V: 16 single-ended or 8 differential, software programmable on a per channel basis as single-ended or differential and unipolar or bipolar

Input Impedance: 10M Ohm

Maximum Input Voltage: ±12V relative to analog common

Over-Voltage Protection: ±25 V

Ranges: Software or sequencer selectable on a per channel basis

/5500MF

Unipolar: 0-10V

Bipolar: ±10V

/5501MF & /5501MF-V

Unipolar: 0-10V, 0-5V, 0-2.5V, 0-1.25V

Bipolar: ±10V, ±5V, ±2.5V, ±1.25V

Triggering

Trigger Sources: Software, onboard pacer, or external TTL

Digital Trigger

Logic Level Range: 0.8V low, 2V high

Software Trigger

Trigger can be initiated under program control

Pre and post triggering

Analog Outputs

/5501MF-V only

Channels: 2

Resolution: 16 bit

Output Voltage Ranges: ±10V or 0 to 10V (software selectable)

Output Current: ±5 mA

Gain Error: Adjustable to zero

Settling Time: 10 µs for full-scale step

Clock Sources: 3, programmable; 1. Software Pacer, 2. Internal Pacer, 3. External TTL

Digital I/O

/5500MF

Channels: 16

Ports: 2 x 8 bit; each port is software programmable as input or output

I/O Levels: TTL

Maximum Output Current

Low: 24 mA (sinking)

High: 24 mA (sourcing)

/5501MF, /5501MF-V

Channels: 16 accessible from main I/O connector, 32 accessible from two auxiliary I/O connectors

Ports: 2 x 8 bit. Each port is software programmable as input or output.

I/O Levels: TTL

Maximum Output Current

Low: 24 mA (sinking)

High: 24 mA (sourcing)

Auxiliary Digital I/O

/5501MF, /5501MF-V

Channels: 32 accessible from 2 auxiliary digital I/O connectors

Ports: 2 x 16 bit. Each port is software programmable as input or output.

Maximum Output Current

Low: 4 mA (sinking)

High: 8 mA (sourcing)

Counter

Channels: 2 x 16-bit

Frequency Measurement Rate: 900 kHz

Trigger Level: TTL

* Other ranges are available; contact factory

ADAC/5500™ Series

Ordering Information

Ordering Information

Description

12-bit, 100-kHz PCI data acquisition board with 8 analog inputs, 16 digital I/O, and two counter-timers; includes CD ROM with all documentation, free PlotterX Plus software, ADLIB-WDM API library for Windows® for C/C++ and Visual Basic®, and drivers for LabVIEW®

ADAC/5500MF

12-bit, 100-kHz PCI data acquisition board with 16 analog inputs, 48 digital I/O, and two counter-timers; includes CD ROM with all documentation, free PlotterX Plus software, ADLIB-WDM API library for Windows for C/C++ and Visual Basic, and drivers for LabVIEW

ADAC/5501MF

Same as ADAC/5501MF but with two 16-bit analog outputs

ADAC/5501MF-V

Termination board with screw-terminals for access to ADAC/5500MF I/O; connects to ADAC/5500MF via a CA-G55 or CA-G56 cable

ADAC-TB-8

Termination board with screw-terminals for access to ADAC/5501MF, and /5501MF-V I/O; connects via a CA-G55 or CA-G56 cable

ADAC-TB-16

Termination board with screw-terminals for access to ADAC/5500 series auxiliary digital I/O; connects via CA-G17-ADAC and CA-G37-x-ADAC (optional) cables

ADAC-DC-37

Part No.

Cables

Description

Expansion cable and connector bracket for accessing auxiliary digital I/O channels on ADAC/5501MF, and /5501MF-V; connects to auxiliary digital I/O header on /5500 series boards and provides D37 connector and PC mounting bracket to be installed on host PC.

Part No.

Provides access to 16 auxiliary digital I/O channels; two CA-G17-ADAC cables are required to access all 32 auxiliary digital I/O channels

CA-G17-ADAC

Expansion cable for connecting ADAC-DC-37 auxiliary digital I/O termination board to CA-G17-ADAC connector bracket; two CA-G37-x-ADAC cables are required to access all 32 auxiliary digital I/O channels

3 ft. expansion cable

CA-G37-3-ADAC

6 ft. expansion cable

CA-G37-6-ADAC

68-conductor ribbon expansion cable, mates with ADAC/5500 series boards and the ADAC-TB-16, or ADAC-TB-8, 3 ft.

CA-G55

68-conductor shielded expansion cable, mates with ADAC/5500 series boards and the ADAC-TB-16, or ADAC-TB-8, 3 ft.

CA-G56

68-conductor shielded expansion cable, mates with ADAC/5500 series boards and the ADAC-TB-16, or ADAC-TB-8, 6 ft.

CA-G56-6

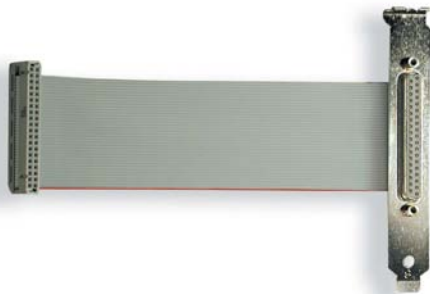

CA-G17-ADAC expansion cable and connector bracket



CA-G55, 68-conductor expansion cable



CA-G56, 68-conductor shielded expansion cable